

Antibodies for Cancer Research

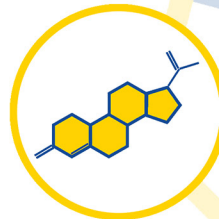

Abbexa is a supplier of biological tools, providing the scientific community with Primary Antibodies, Secondary Antibodies, Proteins and Peptides, ELISA kits and Enzymes as well as other kits and tools for use in research.

Working with various laboratories around the world, we aim to develop relevant, high quality, tested products for the biomedical research market.

CTLA-4

CTLA4 is a **CD28 homologue**, a protein receptor that functions as an immune checkpoint by negatively regulating T-lymphocyte immune responses.

CD28 and CTLA4 compete for CD80 and CD86; CTLA4 has a higher binding affinity, and can therefore sequester the costimulatory CD28 secondary signal for T cell activation.

If CTLA-4 signalling is greater than CD28, T lymphocytes undergo anergy (resulting in reduced: IL-2 production, proliferation, and survival).

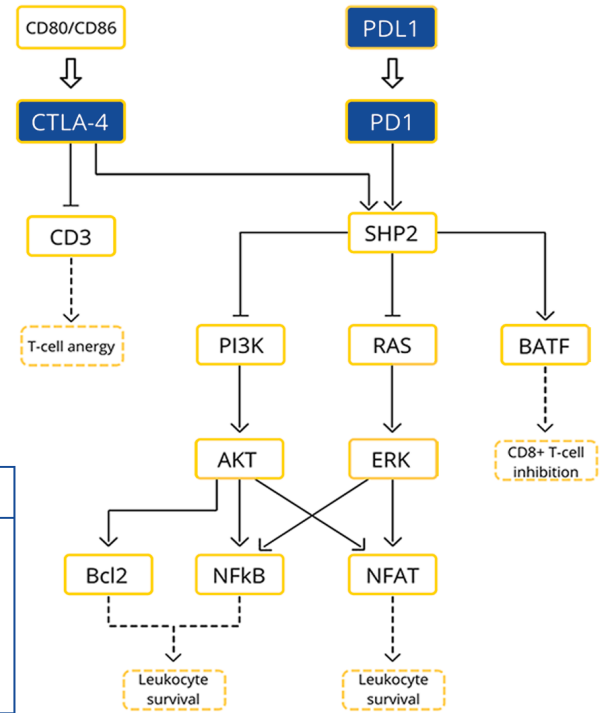

abx104330

Sizes: 100µl, 200µl, 1ml
 Reactivity: Human
 Host: Rabbit
 Clonality: Polyclonal
 Tested Applications: WB, IHC, IF/ICC
 Immunogen: Gly52-Cys211

abx104331

Sizes: 100µl, 200µl, 1ml
 Reactivity: Mouse
 Host: Rabbit
 Clonality: Polyclonal
 Tested Applications: WB, IHC, IF/ICC
 Immunogen: Val45-Ser185

abx104332

Sizes: 100µl, 200µl, 1ml
 Reactivity: Rat
 Host: Rabbit
 Clonality: Polyclonal
 Tested Applications: WB, IHC, IF/ICC
 Immunogen: Thr41-Lys192

abx172039

Sizes: 100µl, 200µl, 1ml
 Reactivity: Human
 Host: Mouse
 Clonality: Monoclonal
 Tested Applications: WB, IHC, IF/ICC
 Immunogen: Gly52-Cys211

abx117193

Sizes: 100µl
 Reactivity: Human
 Host: Rabbit
 Clonality: Polyclonal
 Tested Applications: ELISA, WB, IHC
 Immunogen: A synthetic peptide of human CTLA4
 Isotype: IgG

abx414774

Sizes: 0.25mg, 0.1mg
 Reactivity: Mouse
 Host: Hamster
 Clonality: Monoclonal
 Tested Applications: ELISA, WB, IF/ICC, FCM, IP
 Immunogen: Extracellular portion of mouse CD152 fused to a mouse IgG2a.
 Isotype: IgG

abx333777

Sizes: 20µg, 50µg, 100µg, 200µg, 1mg
 Reactivity: Human
 Host: Rabbit
 Clonality: Polyclonal
 Tested Applications: ELISA, IF/ICC
 Immunogen: 36-161 AA
 Isotype: IgG2b Kappa

abx139386

Sizes: 0.1 mg
 Reactivity: Human
 Host: Mouse
 Clonality: Monoclonal
 Tested Applications: IHC-F, IF/ICC, FCM, IP
 Immunogen: Human CD152-IgG heavy chain fusion protein.
 Isotype: IgG2a

abx335291

Sizes: 20µg, 50µg, 100µg, 200µg, 1mg
 Reactivity: Human
 Host: Rabbit
 Clonality: Polyclonal
 Tested Applications: ELISA
 Immunogen: 36-161AA
 Isotype: IgG
 Conjugation: Biotin

abx335290

Sizes: 20µg, 50µg, 100µg, 200µg, 1mg
 Reactivity: Human
 Host: Rabbit
 Clonality: Polyclonal
 Immunogen: 36-161AA
 Isotype: IgG
 Conjugation: 290 - FITC

abx335289

Sizes: 20µg, 50µg, 100µg, 200µg, 1mg
 Reactivity: Human
 Host: Rabbit
 Clonality: Polyclonal
 Tested Applications: ELISA
 Immunogen: 36-161AA
 Isotype: IgG
 Conjugation: 289 - HRP

PDL1, PD1

PD-1/PD-L1 signalling pathway negatively regulates **immune responses**, preventing an autoimmune response against native cells in immune-privileged sites and mediating tumour immunity.

PD-1 is an immune checkpoint expressed on T lymphocytes. Ligands to PD-1 include: PD-L1 and PD-L2. PD-L1 expression on 'normal' tissues is a crucial mechanism of physiological peripheral immune tolerance to negatively regulate autoimmune responses. PD-L1 is expressed on cancer cells and helps tumours evade the immune system, creating an immunosuppressive environment.

If PD-1 is bound to PD-L1, it causes anergy of the lymphocyte, preventing T-cell mediated destruction of cells, including tumour cells.

PDL1

abx274655

Sizes: 100µl, 200µl, 1ml
Reactivity: Human
Host: Mouse
Clonality: Monoclonal
Tested Applications: WB, IHC, IF/ICC, IP
Immunogen: Pro24-Pro234
Isotype: IgG
Conjugation: Biotin

abx130336, abx129655

Sizes: 100µl, 200µl, 1ml
Reactivity: 336 - Rat, 655 - Mouse
Host: Rabbit
Clonality: Polyclonal
Tested Applications: WB, IHC, IF/ICC, IP
Immunogen: Ser34-Val241

PD1

abx004272

Sizes: 20µl, 50µl, 100µl, 200µl
Reactivity: Human, Mouse
Host: Rabbit
Clonality: Polyclonal
Tested Applications: ELISA, WB
Immunogen: 1-80 AA
Isotype: IgG

abx128729

Sizes: 100µl, 200µl, 1ml
Reactivity: Human
Host: Rabbit
Clonality: Polyclonal
Tested Applications: WB, IHC, IF/ICC
Immunogen: Leu41-Ala132

abx174170

Sizes: 100µl, 200µl, 1ml
Reactivity: Human
Host: Mouse
Clonality: Monoclonal
Tested Applications: WB, IHC
Immunogen: Leu41-Ala132
Isotype: IgG2a Kappa

abx306987, abx306986, abx306985

Sizes: 20µg, 50µg, 100µg, 200µg, 1mg
Reactivity: Human
Host: Rabbit
Clonality: Polyclonal
Tested Applications: ELISA
Immunogen: 21-170 AA
Isotype: IgG
Conjugation: 987 - Biotin, 986 - FITC, 985 - HRP

abx114694

Sizes: 100µl
Reactivity: Human
Host: Rabbit
Clonality: Polyclonal
Tested Applications: ELISA, WB, IHC
Immunogen: Human PDCD1
Isotype: IgG

abx318379

Sizes: 20µg, 50µg, 100µg, 200µg, 1mg
Reactivity: Human
Host: Rabbit
Clonality: Polyclonal
Tested Applications: ELISA, WB, IHC, IF/ICC
Immunogen: 21-170AA
Isotype: IgG

abx137435

Sizes: 5µg, 20µg, 100µg
Reactivity: Human
Host: Rabbit
Clonality: Monoclonal
Tested Applications: ELISA, WB
Immunogen: 21-167 AA
Isotype: IgG2b

PDL1, PD1

abx140406

Sizes: 0.1mg
Reactivity: Human, Monkey
Host: Mouse
Clonality: Monoclonal
Tested Applications: IHC-F, FCM
Immunogen: Full Length Human CD274
Isotype: IgG2b

abx001385

Sizes: 20µl, 50µl, 100µl, 200µl
Reactivity: Human, Mouse, Rat
Host: Rabbit
Clonality: Polyclonal
Tested Applications: WB, IHC, IF/ICC
Immunogen: 19-238 AA
Isotype: IgG

abx236281

Sizes: 100µg
Reactivity: Human, Mouse, Pig
Host: Mouse
Clonality: Monoclonal
Tested Applications: ELISA, WB, IHC, IF/ICC
Immunogen: PD-L1/CD274 fusion protein
Isotype: IgG1

abx179111

Sizes: 100µl, 200µl, 1ml
Reactivity: Rat
Host: Mouse
Clonality: Monoclonal
Tested Applications: WB, IHC, IF/ICC, IP
Immunogen: Ser34-Val241
Isotype: IgG2a Kappa

abx430491

Sizes: 200µl
Reactivity: Human
Host: Goat
Clonality: Polyclonal
Tested Applications: P-ELISA, WB, IF/ICC, FCM
Immunogen: C-Terminus: CKKQSDTHLEET
Isotype: IgG

abx132278

Sizes: 100µl, 200µl, 1ml
Reactivity: Human
Host: Mouse
Clonality: Monoclonal
Tested Applications: WB, IHC, IF/ICC, IP
Immunogen: Pro24-Pro234

abx104347

Sizes: 100µl, 200µl, 1ml
Reactivity: Human
Host: Rabbit
Clonality: Polyclonal
Tested Applications: WB, IHC, IF/ICC, IP
Immunogen: Pro24-Pro234

abx111472

Sizes: 100µl
Reactivity: Human, Mouse, Rat
Host: Rabbit
Clonality: Polyclonal
Tested Applications: ELISA, WB, IHC
Immunogen: Human CD274
Isotype: IgG

abx412030

Sizes: 0.1mg
Reactivity: Human
Host: Rabbit
Clonality: Polyclonal
Tested Applications: WB, IHC, IF/ICC
Immunogen: A peptide corresponding to a 17 amino acid sequence from near the centre of Human CD274.
Isotype: IgG

abx140453, abx140427

Sizes: 100 tests
Reactivity: Human, Monkey
Host: Mouse
Clonality: Monoclonal
Tested Applications: IHC, FCM, FUNC
Immunogen: Full length Human CD274
Isotype: IgG2b
Conjugation: 453 - APC, 427 - PE

abx224294

Sizes: 100µl
Reactivity: Human
Host: Mouse
Clonality: Mouse
Tested Applications: ELISA, WB, FCM
Immunogen: 24-153 AA of human CD274

abx320158

Sizes: 50µl, 100µl
Reactivity: Human
Host: Rabbit
Clonality: Polyclonal
Tested Applications: ELISA, IHC
Immunogen: 19-238 AA
Isotype: IgG

abx430492

Sizes: 200µl
Reactivity: Human
Host: Goat
Clonality: Polyclonal
Tested Applications: P-ELISA, WB, IHC
Immunogen: C-Terminus CKKQSDTHLEET
Isotype: IgG
Conjugation: Biotin

IDO1

IDO1 is a tryptophan catabolic enzyme; it catalyses the conversion of tryptophan to kynurenine.

The increase in kynurenine (and subsequent depletion in tryptophan) has immunosuppressive effects, by activating T regulatory cells (Tregs) and myeloid-derived suppressor cells, which then inhibits the functions of effector T and natural killer cells.

Although this is a crucial mechanism in 'normal' immune cell functioning, cancer cells exploit this pathway (IDO1 is overexpressed in vast majority of cancers) to promote tumour progression, neovascularisation, and cancer immune evasion.

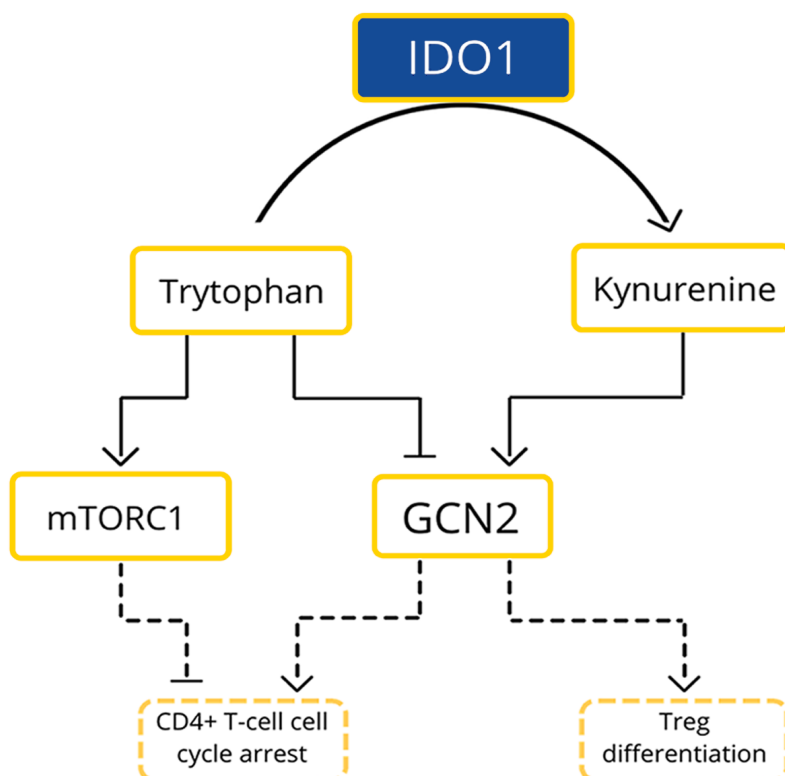

abx234127

Sizes: 100µg
Reactivity: Human, Mouse, Rat
Host: Rabbit
Clonality: Polyclonal
Tested Applications: ELISA, WB, IHC
Immunogen: Indoleamine 2,3-dioxygenase 1
Isotype: IgG

abx415777

Sizes: 0.1mg
Reactivity: Human, Mouse
Host: Mouse
Clonality: Monoclonal
Tested Applications: WB, IHC
Immunogen: Peptide corresponding to amino acids 78-184 of human IDO fused to GST.
Isotype: IgG3

abx109906

Sizes: 20µg, 50µg, 100µg, 200µg, 1mg
Reactivity: Human
Host: Rabbit
Clonality: Polyclonal
Tested Applications: ELISA, WB, IHC, IF/ICC
Immunogen: Recombinant human indoleamine 2,3-dioxygenase 1 protein (1-403 AA)
Isotype: IgG

abx412567

Sizes: 0.1ml
Reactivity: Human, Monkey
Host: Sheep
Clonality: Polyclonal
Tested Applications: WB, IHC
Immunogen: Recombinant human indoleamine 2,3-dioxygenase.
Isotype: IgG

abx106970, abx105553, abx108391

Sizes: 20µg, 50µg, 100µg, 200µg, 1mg
Reactivity: Human
Host: Rabbit
Clonality: Polyclonal
Tested Applications: ELISA
Immunogen: Recombinant human indoleamine 2,3-dioxygenase 1 protein (1-403 AA)
Isotype: IgG
Conjugation: 553 - Biotin, 970 - FITC, 391 - HRP

abx113123

Sizes: 100µl
Reactivity: Human
Host: Rabbit
Clonality: Polyclonal
Tested Applications: ELISA, WB
Immunogen: Human IDO1
Isotype: IgG

TNFRSF4

The **OX40/OX40L** pathway promotes a **Th2 response**; this favours humoral B cell response, resulting in the production of large antibody quantities (which provide little support for immune responses against cancer cells).

The Th1 response is dampened due to the high levels of nearby IL4, causing a reduction in the numbers of macrophages and CD8+ T cells, cells which are more effective than B cells and granulocytes for clearing cancers.

abx414760

Sizes: 0.25mg
Reactivity: Rat
Host: Mouse
Clonality: Monoclonal
Tested Applications: ELISA, FCM
Immunogen: ACI-S1 rat T-cell lymphoma cell line.
Isotype: IgG1

abx413479

Sizes: 0.25mg
Reactivity: Mouse
Host: Rat
Clonality: Monoclonal
Tested Applications: IHC, FCM
Immunogen: Rat CD4 and mouse CD134 ligand Chimaeric protein.
Isotype: IgG1

abx339142

Sizes: 50µl, 100µl
Reactivity: Human
Host: Rabbit
Clonality: Polyclonal
Tested Applications: ELISA, IHC
Immunogen: Synthetic peptide of human TNFSF4
Isotype: IgG

abx026700

Sizes: 80µl, 400µl
Reactivity: Human
Host: Rabbit
Clonality: Polyclonal
Tested Applications: ELISA, WB
Immunogen: KLH-conjugated synthetic peptide between 102-131 amino acids from the Central region of human TNFSF4.
Isotype: IgG

abx323445, abx323446, abx322832

Sizes: 50µg, 100µg
Reactivity: Human
Host: Rabbit
Clonality: Polyclonal
Tested Applications: 445/446 - ELISA, WB, 832 - ELISA, IF/ICC
Immunogen: Synthesized peptide derived from the internal region of human OX40L
Isotype: IgG

abx025358

Sizes: 100µl
Reactivity: Human
Host: Mouse
Clonality: Monoclonal
Tested Applications: ELISA, WB
Immunogen: KLH-conjugated synthetic peptide between 97-125 amino acids from human TNFSF4.
Isotype: IgM

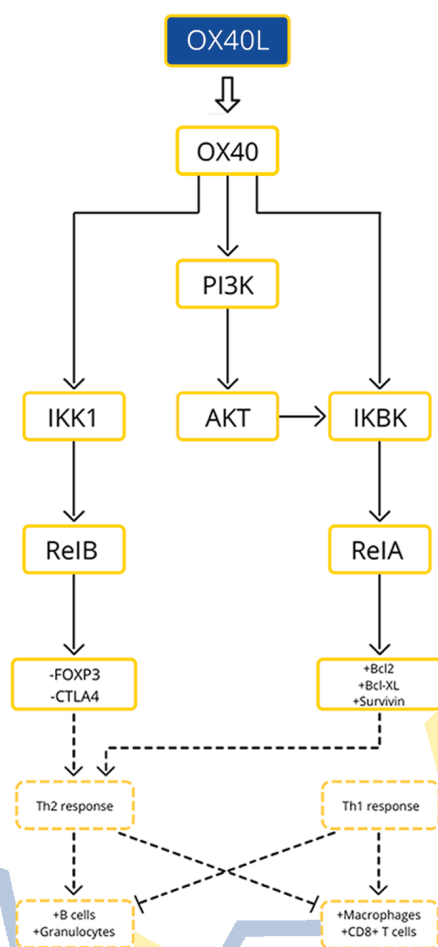

DMBT1

Deleted in Malignant Brain Tumours 1 protein (DMBT1) is a putative tumour suppressor originally identified by its disappearance in a cell line derived from a brain tumour.

It is thought to interact with various different immune cells, recruiting them to nearby pathogens and to tumour cells.

The deletion of DMBT1 is typically mediated by the loss of the q end from chromosome 10 (q26.13 or above), which occurs in around 80% of glioblastoma multiforme cases.

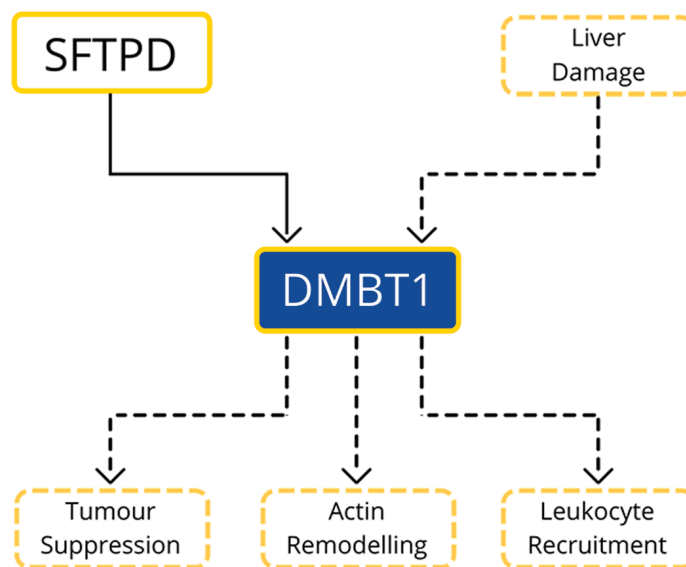

abx176133
Sizes: 100µl, 200µl, 1ml Reactivity: Human Host: Rabbit Clonality: Polyclonal Tested Applications: WB, IHC, IF/ICC Immunogen: Cys2008-Arg2413

abx376242
Sizes: 100µl Reactivity: Human, Mouse, Rat Host: Rabbit Clonality: Polyclonal Tested Applications: IHC Immunogen: Synthesized peptide derived from part region of human protein

abx213667
Sizes: 50µl, 100µl Reactivity: Human, Mouse, Rat Host: Rabbit Clonality: Polyclonal Tested Applications: ELISA, IHC Immunogen: Synthetic Peptide of human DMBT1 Isotype: IgG

PDL1, PD1

Cancer Immunotherapy: Targeting PDL1 / PD1

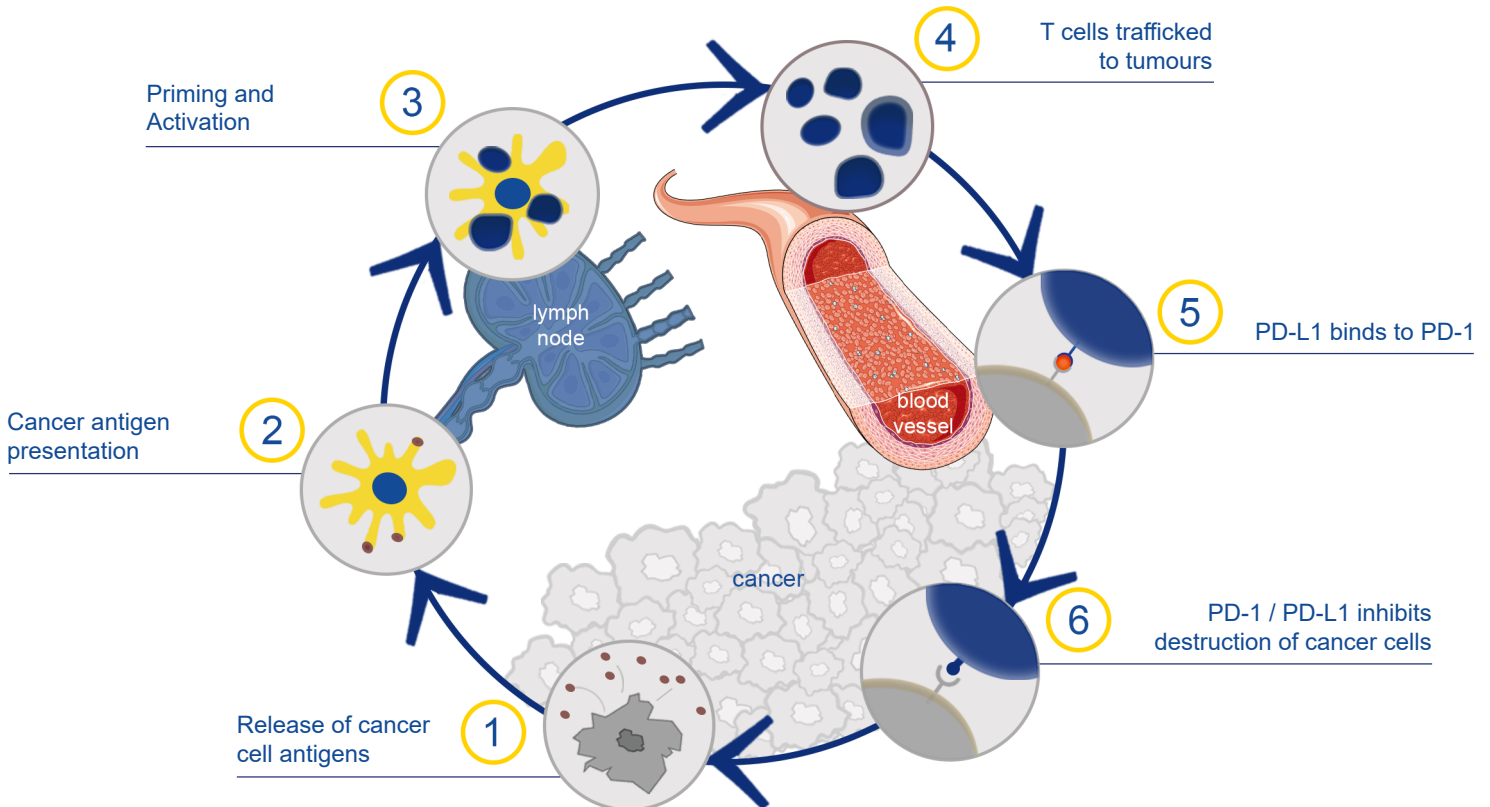

The **PD-1/ PD-L1** pathway negatively regulates immune responses. PD-1 / PD-L1 binding leads to down-regulation of T-cell activity, preventing T-cell mediated cell destruction.

PD-L1, a ligand to PD-1, is over-expressed on cancer cells, creating an immunosuppressive environment that helps tumours to evade the immune system.